



External Assessment

NCFE Level 2 Certificate in Engineering Studies (601/4532/8)

Unit 02 Introduction to engineering drawing (L/506/3766)

Past Paper

Assessment window: 20 January 2020 to 31 January 2020

Task 2

Time allowed – 2 hours

Complete your details below:

Centre name		Centre number	
Learner name		Learner number	

Instructions for learners

- Read Task 2 carefully and make sure that you understand what you need to do to complete Task 2 Part A and Part B.
- You **MUST** attempt **all** of the questions in Task 2 to address all assessment criteria. You cannot achieve a Pass grade unless you meet the required standard in all of the questions.
- If you are aiming for a Merit or Distinction, it is particularly important that you are familiar with what these grades require as you work through the tasks.
- Write your responses to the questions in the spaces provided. If you need more space you may use extra paper.
- If you are using a word processor, you **must** make sure that all of your work is printed out.
- Make sure that any printouts or extra paper is securely attached to this assessment paper and labelled clearly with:
 - your name and learner number
 - centre name and centre number
 - task and question number.
- Your 2D drawing completed for Task 2 may be hand-drawn or produced using a computer. If you produce your drawings on a computer you **must** print out a hard copy. You **must** submit the hard copy only.
- At the end of the assessment hand all documents over to your Invigilator.

You are **not** allowed to use the internet during this external assessment.

Please turn over for the list of equipment you will need.

This page is intentionally left blank

Past Paper

This is a list of the equipment you will need for this external assessment.

Essential:

- 2H and 4H pencils
- A3/A4 plain paper
- ruler
- set square/T-square
- compass
- protractor
- eraser.

Optional (this list is not exhaustive):

- drawing board
- clutch pencil
- templates
- French curves
- CAD software
- additional H-type pencils.

DO NOT TURN OVER UNTIL YOU ARE INSTRUCTED TO DO SO BY THE INVIGILATOR.

Scenario

You are a Design Engineer for a fabrication company. You have been given a sketch of a heavy duty shaft bracket.

The hand-drawn sketch you have been given is shown below.

Task 2

For Task 2 there are two parts, **Part A** and **Part B**.

You must ensure your work in Task 2 addresses assessment criteria 1.3, 2.1, 2.2, 2.3 and 2.4. You can refer to the relevant assessment criteria throughout the task.

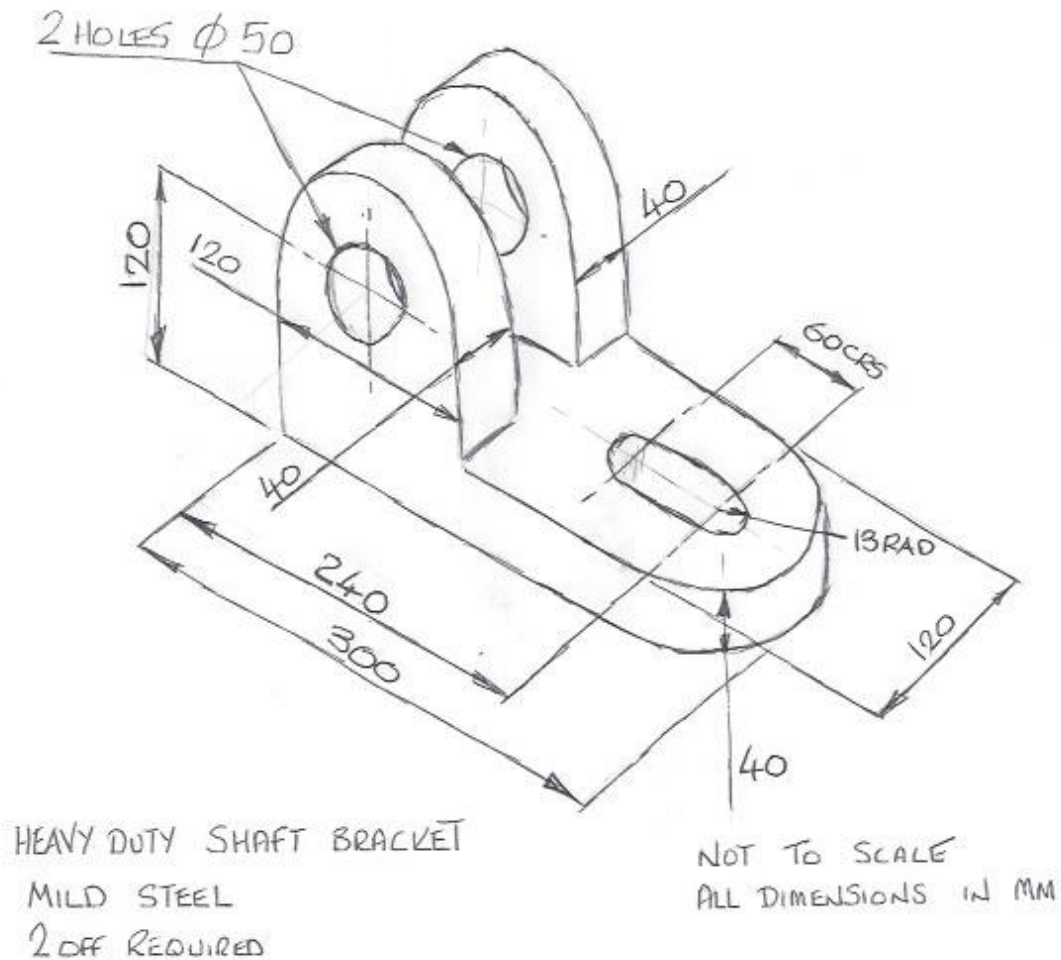

Part A

Look at the sketch on page 4.

Your task is to produce a **2D** drawing which will be used to make the heavy duty shaft bracket.

As you plan your drawing, answer the following questions.

1. Why is proportion important in the sketch on page 4?

.....

.....

.....

.....

.....

.....

.....

2. What size of paper will you choose? Why are you going to use this size?

.....

.....

.....

.....

.....

.....

.....

3. What scale are you going to use for your drawing of the heavy duty shaft bracket?
Why are you going to use this scale?

.....

.....

.....

.....

.....

.....

.....

Assessment criterion	Pass	Merit	Distinction
1.3 Describe the purpose of scale and proportion in engineering drawing	Learners will describe the purpose of scale and proportion in engineering drawing	Learners will coherently describe the purpose of scale and proportion in engineering drawing	Learners will describe the purpose of scale and proportion in engineering drawing showing critical judgement

4. How will you decide where to place your component on the drawing sheet?

.....

.....

.....

.....

.....

.....

.....

5. Apart from the heavy duty shaft bracket itself, what information do you need to include on your drawing?

.....

.....

.....

.....

.....

.....

.....

Assessment criterion	Pass	Merit	Distinction
2.1 Demonstrate the correct layout of a design sheet for 2D and 3D engineering drawings	Learners will demonstrate the correct layout of a basic design sheet for 2D and 3D engineering drawings	Learners will demonstrate the correct layout of a detailed design sheet for 2D and 3D engineering drawings	Learners will skilfully demonstrate the correct layout of a sophisticated design sheet for 2D and 3D engineering drawings

Part B

Now produce your **2D** drawing.

Use the sketch on page 4.

The drawing **must** be:

- 2D
- correctly laid out on A4 or A3 paper
- drawn to scale. You should choose the scale you think is most appropriate and indicate this in the title block
- drawn using appropriate drawing tools and equipment. You can decide whether to draw by hand or use a computer.

If you are using CAD, you **must** provide evidence to show the process involved in the production of your drawing by demonstrating which tools you have used to create the various aspects of the drawing. Evidence could be screenshots with annotations.

If you produce your drawing on a computer it **must** be printed out and submitted as a **hard copy only**.

Assessment criteria	Pass	Merit	Distinction
2.2 Apply appropriate scales to all drawings	Learners will apply appropriate scales to all drawings	Learners will apply appropriate and realistic scales to all drawings	Learners will skilfully apply appropriate and realistic scales to all drawings
2.3 Demonstrate the accurate use of drawing tools and equipment	Learners will demonstrate the accurate use of drawing tools and equipment	Learners will demonstrate the accurate use of drawing tools and equipment showing experimentation	Learners will skilfully demonstrate the accurate use of drawing tools and equipment showing experimentation
2.4 Present their final 2D and 3D engineering drawings showing evidence of the process involved in its production	Learners will present their final 2D and 3D engineering drawings showing evidence of the process involved in its production	Learners will present their final 2D and 3D engineering drawings showing evidence of the process involved in its production, justifying their choices	Learners will present their final 2D and 3D engineering drawings showing evidence of the process involved in its production showing critical judgement

What you need to hand in after your external assessment.

At the end of the timed external assessment you will hand in the following work to your Invigilator:

- this external assessment paper
- any extra paper you have used, securely attached
- your 2D drawing.

Make sure that any extra paper is clearly identified with:

- your name and learner number
- your centre name and centre number
- the task and question number.

Any remaining time can be spent checking your responses to Task 2.

This is the end of the assessment.